



C-COM DISCLAIMER

Legal Notice:

Certain written and oral statements included in this presentation may constitute “forward-looking information” reflecting the current expectations of C-COM Satellite Systems Inc. (“C-COM”). For example, statements about market opportunities, C-COM’s ability to capitalize on such opportunities, new products, features and functionality, potential growth rates, extrapolated revenues and other statements about any future expectation or event, are all forward-looking information. This information reflects C-COM’s current beliefs with respect to future events and is based on information currently available to management. Forward-looking information involves significant known and unknown risks, uncertainties and assumptions. Many factors could cause actual results, performance or events to be materially different from those implied or expressed by forward-looking information in this presentation. Should one or more of these risks or uncertainties materialize, or should assumptions underlying the forward-looking information prove incorrect, actual results, performance or events could vary materially from those expressed by forward-looking information in this presentation. Although forward-looking information contained in this presentation is based upon what C-COM believes to be reasonable assumptions, C-COM cannot provide assurances that actual results, performance or events will be consistent with the forward-looking information in this presentation and cautions that undue reliance should not be placed on the forward-looking information. This presentation was originally given on May 4th, 2022. The forward-looking information is given as of the date on which this presentation was first given and may be out of date or proven inaccurate by the time this presentation is viewed. C-COM does not assume any obligation to update or revise this presentation to reflect new events or circumstances, except as required by law. Viewers should view the totality of C-COM’s public disclosure available at www.SEDAR.com including C-COM’s most recent MD&A located at www.SEDAR.com which describes risk factors associated with C-COM’s business and an investment in C-COM. Those risk factors are incorporated into this presentation by reference.

Nothing in this presentation is intended to be an offer to sell or a solicitation for offers to buy securities of C-COM in any jurisdiction. C-COM was not undertaking or contemplating a sale of securities or accepting offers to acquire securities from C-COM as of the date on which this presentation was first given.

C-COM – Pioneer in Mobile VSAT

- C-COM is an Ottawa-based technology company focused on research, development and design of fully motorized, auto-deploy, mobile satellite antenna products (iNetVu®).
- Established in 1997, C-COM is one of the largest Comm-On-The-Pause (COTP) mobile VSAT manufacturers in the world.
- Company is developing highly disruptive antenna technology (electronically steerable phased array).

Employees: 33
Exchange: **TSXV: CMI** and **OTCQB: CYSNF**
Dividend yield: 3.91% (Q1, 2024)



C-COM by the Numbers



- 10,000+:** iNetVu® commercial mobile VSAT systems sold
- 106:** Number of countries in which you will find iNetVu®
- 600+:** Active dealer partners worldwide
- 41:** Models available of the iNetVu® auto-acquire, motorized antenna
- 10:** Modem manufacturers PLUG & PLAY Integrated with iNetVu® (35 different modem models)
- 12:** Sizes of antenna available (60cm, 74cm, 75cm, 80cm, 98cm, 1.0m, 1.2m, 1.3m, 1.5m, 1.8m and 2.4m)
- 4:** Formats of antenna (Driveaway, Flyaway, Manpack, Fixed Motorized)
- 4:** Bands of antenna available (Ka, Ku, C & X band)
- \$25.6 million:** Working Capital (as of February, 2024)
- \$25 million:** Shareholder Dividends Paid (as of February, 2024)
- 48:** Consecutive Quarterly Dividends
- \$0:** Debt

Note: As of November, 2023. All figures in \$CAD



Commercial Markets Using Mobile SATCOM

- Government
- Military
- Emergency Response
- Disaster Recovery
- Blue Light Vehicles
- Oil & Gas
- Telecom Companies
- Banks
- Broadcasters
- Hospitals
- Schools
- Mining
- Events



Where terrestrial infrastructure is **LIMITED**, **DISRUPTED**, or **NON-EXISTENT**, Broadband Internet via Satellite is the **ONLY** option.

Worldwide Deployment

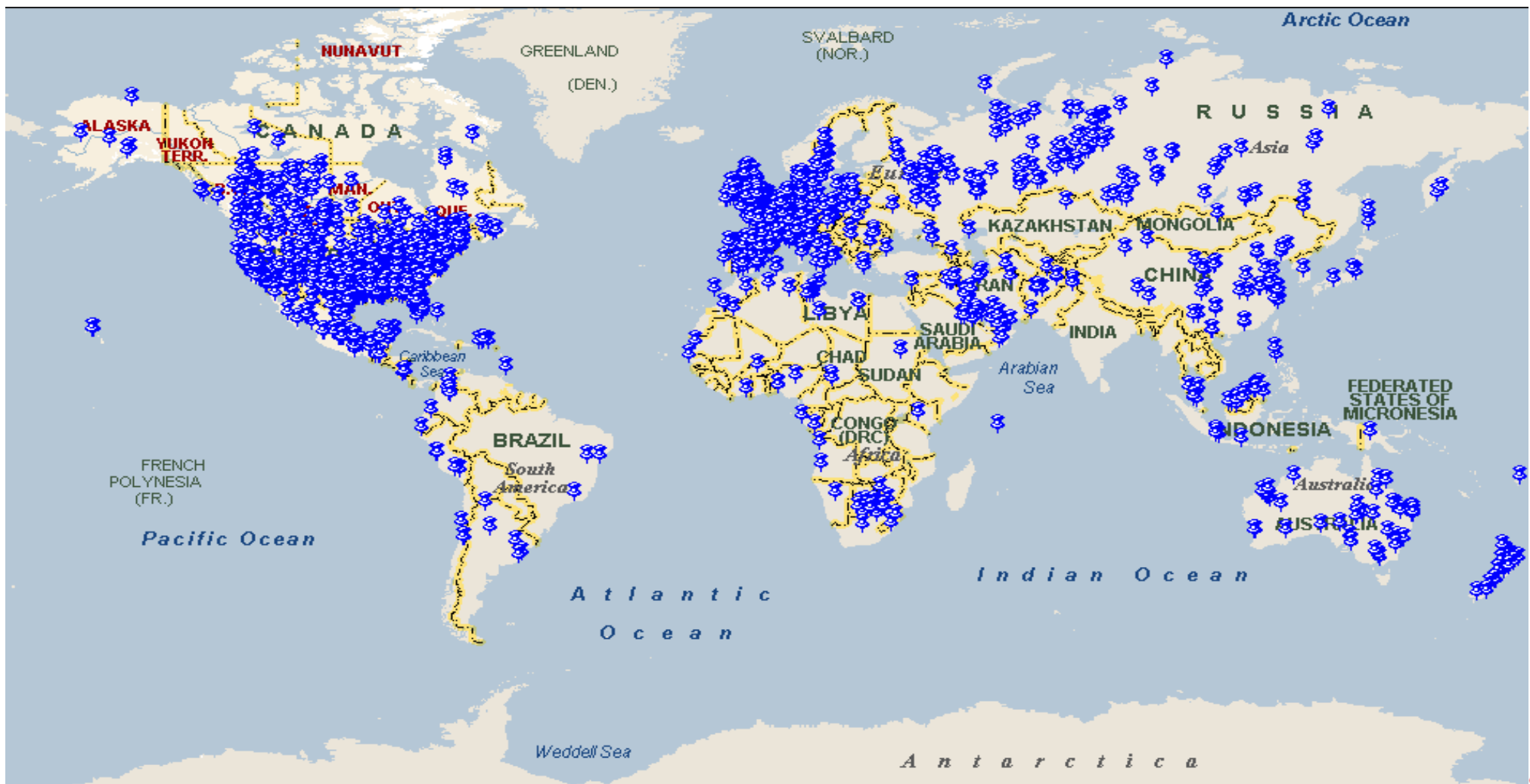

iNetVu® Platforms (75cm – 240cm)



DriveAways



Ka-74/G Ka-75V Ka-75VP/KASAT 980+/982 Ka-98G/V/H/HJUP 1200+ 1202 Ka-1202V Ka-1202G 1501 1801

FlyAways



FLY-74/G FLY-75V FLY-981 FLY-98G/V/H ACFLY-1200 FLY-1202 FLY-1202G/V FLY-1801 MP-60/80/100/130

FMA's (Fixed Motorized Antenna)



FMA-121 FMA-121Ka FMA-180+/181 FMA-241

The iNetVu Controller Series



- Simple stand-alone one touch operation to find satellite and stow antenna
- Typical satellite acquisition time in less than 2 minutes
- Ideal for applications that require a quick, simple setup and reliable connection
- Supports DVB-S1 and DVB-S2/ACM frequencies (modem independent)
- Optimal, high-precision antenna pointing, supports inclined orbit satellites
- Remote access and operation via Network, Web and other Interfaces
- Built-in motion and movement protection for safety
- Integrated with 20+ modems (Hughes, Gilat, Viasat, iDirect, Comtech, iPStar, etc.)
- 7 methods of finding satellite

74cm Auto-Acquire Ka-band DriveAway (Eutelsat, Hughes & Gilat)

Ka

NEW
GEN

iNetVu® Ka-74X



Ka-74G



- G – Eutelsat/Konnect Approved; also compliant with Gilat (SkyEdge) Ka services

Ka-74H-JUP



HUGHES

- H-JUP- Hughes Jupiter modems. The Ka-74HJup is suitable to operate with HNS Jupiter Networks

iNetVu® 7715 Controller

98cm Auto-Acquire Ka-band DriveAway (Hughes, ViaSat, Avanti & Gilat)

Ka

NEW
GEN

iNetVu® Ka-98X

(G/V/H/H-JUP)



iNetVu® 7710 Controller



avanti Approved Compatibility



eutelsat
type approved for KA-SAT

ViaSat

avanti Approved Compatibility



HUGHES

- G - Avanti Approved; Thor7 Type Approved; also compliant with Gilat (SkyEdge) Ka services
- V - Exede by ViaSat / KA-SAT satellites using ViaSat Broadband Modems. Auto beam select is available on the KA-SAT Tooway service.
- H - Hughes Ka-band modems. The Ka-98H is suitable to operate over the Yahsat Yahclick network, and will be adapted as more networks become available.
- H-JUP- Hughes Jupiter modems. The Ka-98HJup is suitable to operate with HNS Jupiter (NA)⁽¹⁾, YAHSAT (MENA)⁽¹⁾ and Avanti⁽¹⁾
- Pod option available

⁽¹⁾Supported Radios: Spaceway or Jupiter. Please specify which radio being used when ordering.
<http://www.avantiplc.com/avanti-approved-compatibility>

New Generation 1.2 m Auto-Acquire Ku-band DriveAway

Ku

NEW
GEN

iNetVu® 1202



Ka-band or Ku-band

- Field Upgradable to Ka-Band
- Low Stow, high-precision antenna pointing, near zero backlash
- Excellent Cross-pol performance
- Based on Eutelsat approved Skyware 1.2m Antenna, Type 125
- Works on all Ku Supported Services
- Characterized with Eutelsat* and Intelsat Compliant
- Patented sleek aerodynamic form (Patent # D696649 & D696650)
- Optimal high-precision antenna pointing
- Wind deflector pod (optional)
- 2-piece thermoset-molded reflector (optional)

1.2 m Auto-Acquire FlyAway

iNetVu® FLY-1202



FLY-1202G



FLY-1202V

- 1.2m FlyAway Antenna
Designed for Ku and X Band
- Low cost, high precision
antenna pointing, near zero
backlash
- Setup less than 15 minutes
- Tool less, Captive H/W
fasteners
- Fits in 4 Transportable Cases,
under 35kg ea.
- Based on Eutelsat approved
1.2m Skyware antenna

iNetVu® Manpack

Ka

Ku

X

NEW
GEN

Manpack systems can be easily configured to provide quick access to satellite communications for any application that requires remote connectivity in a rugged environment.

Ideally suited for applications that require a quick, simple set-up; in vertical markets such as emergency response, disaster management, public safety, broadcast, media and more.



Simple to Assemble and Easy to Use

Manpack



Auto-Pointing System Option
Includes Onboard Controller

MP-60/80/100/130 - Manpack

- Complete satellite acquisition in seconds
- Super quiet operation, no noise
- IP 66 Rating of whole system
- Assembly in 4-5 minutes without tools
- High precision reflector petal can be interchanged among one system and over multiple systems
- Multiple bands support: Ku, Ka, X
- Supports manual operation with handwheels and indicators

iNetVu[®] Manpack - MIL

Ka

Ku

X

NEW
GEN



Manpack Deployment for Film Production in British Columbia



Manpack Deployment in Japan following Typhoon 19





Oil & Gas



FracTech – Texas, USA - 1200



ITC Global - Australia - FLY-1201



Diverselt - Perth, Australia - 1200



TC Communication - Australia 1200



Oil & Gas – Halliburton - 980



Libya - Hermes - 1200



Sinopec - China - 1200



BSC - Beijing - 1200



Satellite News Gathering



**WebTVLive OTT by C2D.eu - RTC
Belgium Broadcaster - Ka-75V**



DDish TV - Mongolia - 1201



**Spar Woman's Day Race - Grintek -
Africa - Ka-98H**



SNG - ViaSat - USA - Ka-75V



**SNG - Newspotter - Eusatnet
(SatSpeed) Germany - Ka-75V**



**CCTV in China - Sichuan
Earthquake - 1200**



SNG - ARY News - Pakistan - 1200



Elections in Angola - Grintek - 1200



Emergency Response



Excelerate – UK - 1200



**Landslide Disaster
JSC Japan - 980**



**Police Command Vehicle
Altegosky – Russia - 1200**



FireTruck - Xian - China - 1200



Fire Department - Japan - 1201



ER - Primetech – UK - Ka-75V



Disaster Recovery - Softbank - 980



Indonesia - 1200



TeleHealth



Telemedicine and Mobile Diagnostic Center Altegrosky - Russia - 1200



Mobile Health - Remote Comm LLC Midland, TX - 1200



Mobile Surgical Satellite Service New Zealand - 1800



Loma Linda University - USA - 1200



Mobile COVID Vaccination Clinic - Hughes - US - 1200



Mobile Health Care Services Siberia - 1200



Breast Screening - NZ - 980



Transnet Phelophepa Health Train Grintek - South Africa - 1200



Military



Polish Military - TTCom - 1800



Military - Russia - 1200 & 980



Russian Police Vehicle - 1200



Military - Russia - 1200



Military - 1200 transported on a Russian IL-76 Cargo Plane



Russian Military - Fly-1201



Military Forward Operations Base - USA FLY-1201 - Carolina Satellite



Vietnam Military Vehicle -980



Telecom



Telecom – TFL – Fiji – 1200



Telecom – TFL – Fiji – 1200



Telecom - Numix -Broadband on Wheels - Malaysia- 1200



Telecom Malaysia Mobile Store Numix - 980



AT&T – UK - 1800



Telecom – China - 980



Telecom Malaysia - Numix - 1200



Telecom Malaysia - Numix -980



Mobile Office



**Gov. pension programme Vox
Telecom – South Africa – Ka-98H**



Peru – FLY-981



Telespazio – Demo – Germany- 981



**Government - Mobile ID Vehicles
Argentina - Telespazio - 1200**



**Mobile Sight Services - UK
Primetech - 750**



**Mobile Office - Eskom
South Africa - 980**



**Mobile Tax Office - Grintek
South Africa - 980 - SARS**



**Youth Services - UK – Primetech -
Ka-75V**

Mobile Banking



NTI Soluciones – Spain - 1200



**South Africa
Grintek - 980**



UK - Primetech - Ka-75V



Numix - Malaysia 981



**Transportable ATM Container
New Zealand - Bay City - 980**



Coris Bank International - 980



Germany - 1200



SATCOM Business Innovating Aggressively

The Satellite business is a \$46B market. Flat Panel Satellite Antennas represent a \$17B opportunity over the next decade.

Many big players, with very ambitious projects, are now getting involved:



OneWeb
(UK+Bharti-
India)
648 Satellites



Musk (SpaceX)
4408 microsats



Bezos (Amazon-Kuiper)
3,236 satellite constellation



Telesat Lightspeed
188



Boeing 132



Gates funding
Kymeta



Entering the **GOLDEN AGE OF** the **SATELLITE BUSINESS?**

O3B, SpaceX, Amazon, Inmarsat, Telesat, Viasat, Intelsat, Hughes, Kepler, Boeing and others have large-scale goals.

All of these grand schemes require antenna design expertise.

All require reliable & high precision ground station antennas.

Can they be cost effective?

Low Cost Phased Array Antenna System for Ka-band Mobile SOTM

- C-COM Satellite Systems, in partnership with the University of Waterloo, is creating its first Phased Array Antenna (PAA).
- C-COM tested its Ka-band Phased Array modules using the company's **patented phase shifter technology** in 2020.
- **The proof-of-concept prototype has been successfully concluded by satellite tests in 2021.**
- The concept is based on modules that are small, but contain everything — the antenna, plus the electronic circuit, parts of the control circuitry, and local memory.

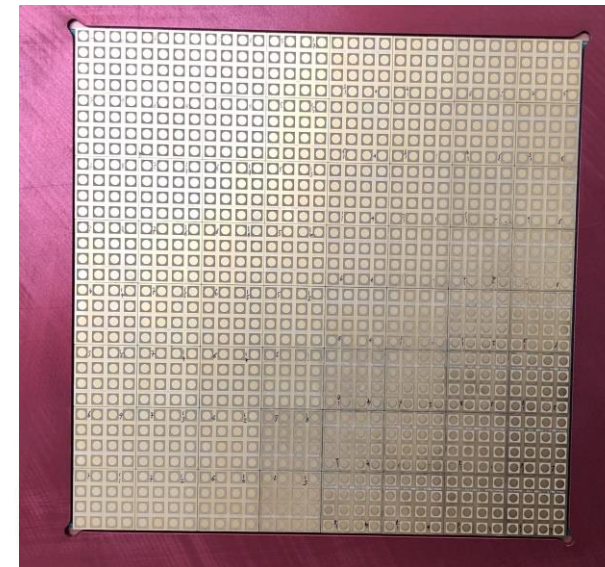
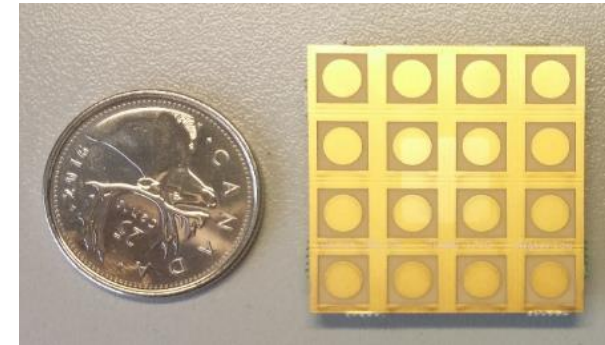

16x64 RX 4x4 Modules
(1024 Elements)

Advantages of Proposed Technology

INTELLIGENT CHIP BASED TECHNOLOGY

- System can have full control over each module
- Can perform electronic beam steering
- Can optimize the beam
- Can electronically scan 360 degrees
- **Scalable**
 - Gain can be increased by adding multiple modules
 - Allows for small building blocks which can be used to make any size of antenna;
- **Conformal**
 - Bends to fit various shaped surfaces

- **Dramatic cost reduction**
 - One antenna consists of several thousands chips, a few hundred antennas could reach a volume of millions of chips.
 - It will be easy to reach “economies of scale”, leading to significant cost savings.
 - Applicable to many vertical markets

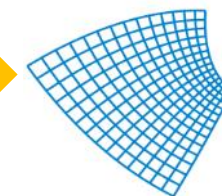
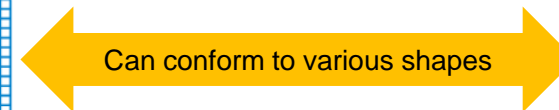
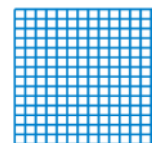
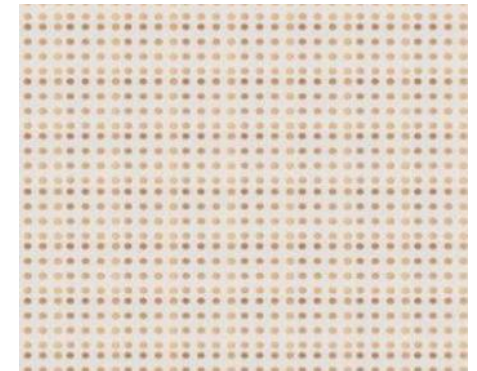
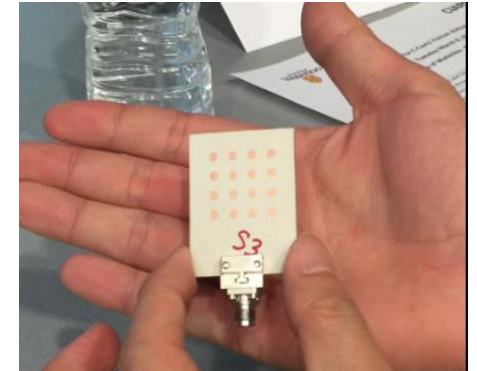

Scalable Architecture: 4x4 to 16x16 to 80x80 Antenna Sub-Arrays



4 x 4 Antenna Sub-Array Module

4X4 Tile

Microstrip-line
feed circuit
containing
variable gain
low noise
amplifier (LNA)
and the BST
phase shifter

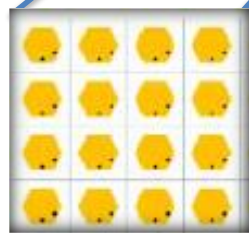

**4x4 Sub-array
Module**

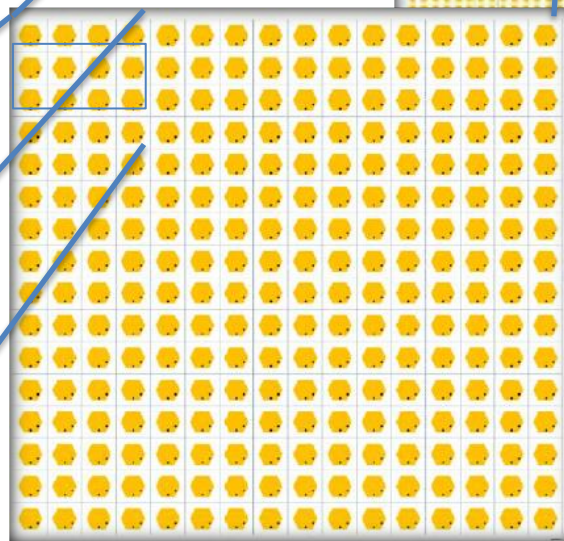

**16x16 Sub-array
Module**

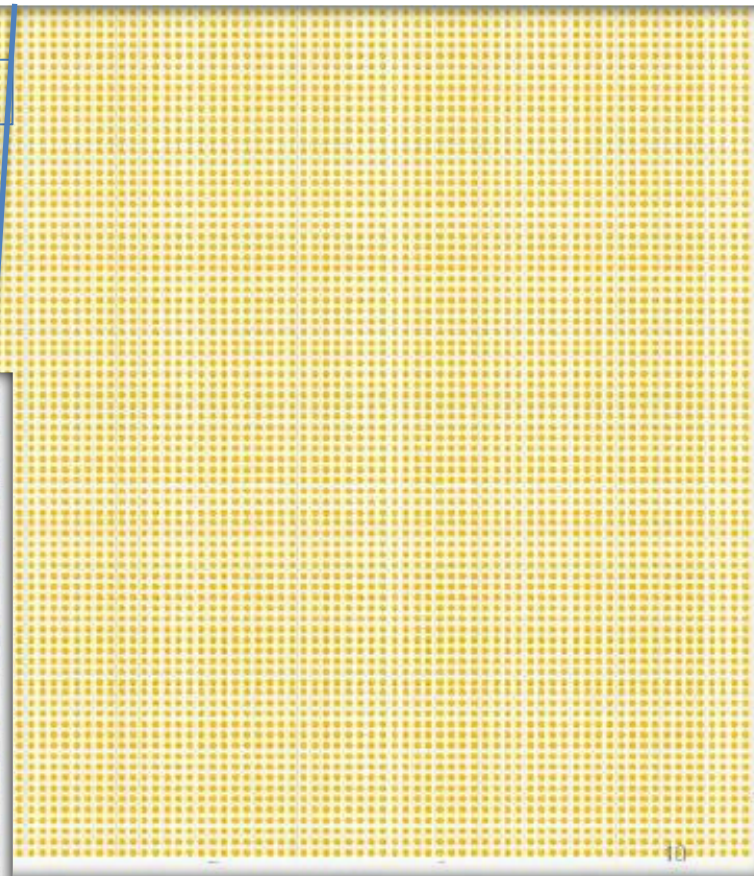

80x80 Array Panel
made of 25 of 16x16 sub-arrays

Flat Panel Antenna vs Parabolic Under Test



Satellite Ground Terminal (GEO, MEO,LEO)



Popular Mechanical Scanning Antenna

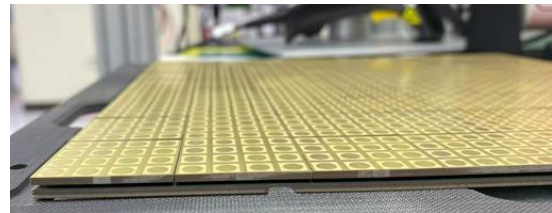
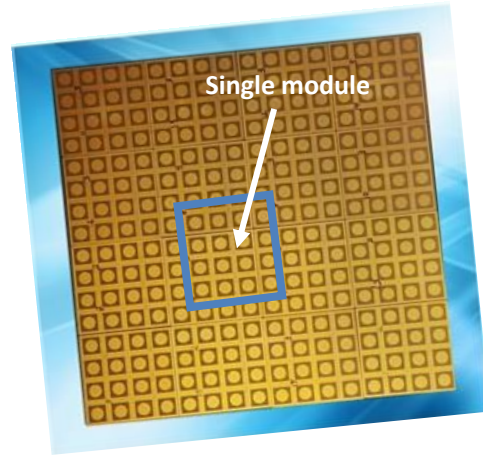

New Generation Antenna

**Flat Electronic Scanning Antenna
under Development by C-COM**



NSR's Flat Panel Satellite Antenna Analysis

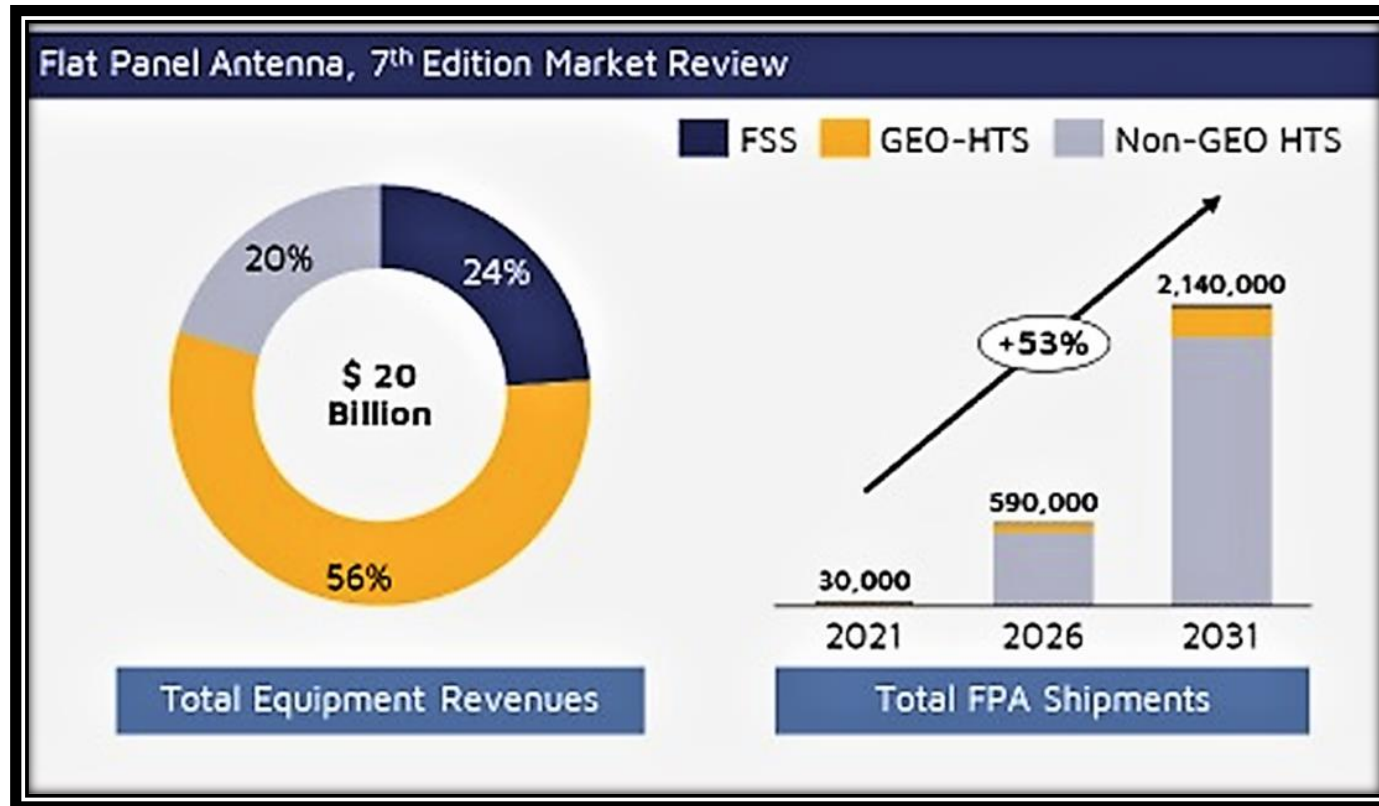

* Credit by NSR - Northern Sky Research

NSR's Flat Panel Market Penetration Rate

Global FPA Market FPA Penetration Rate

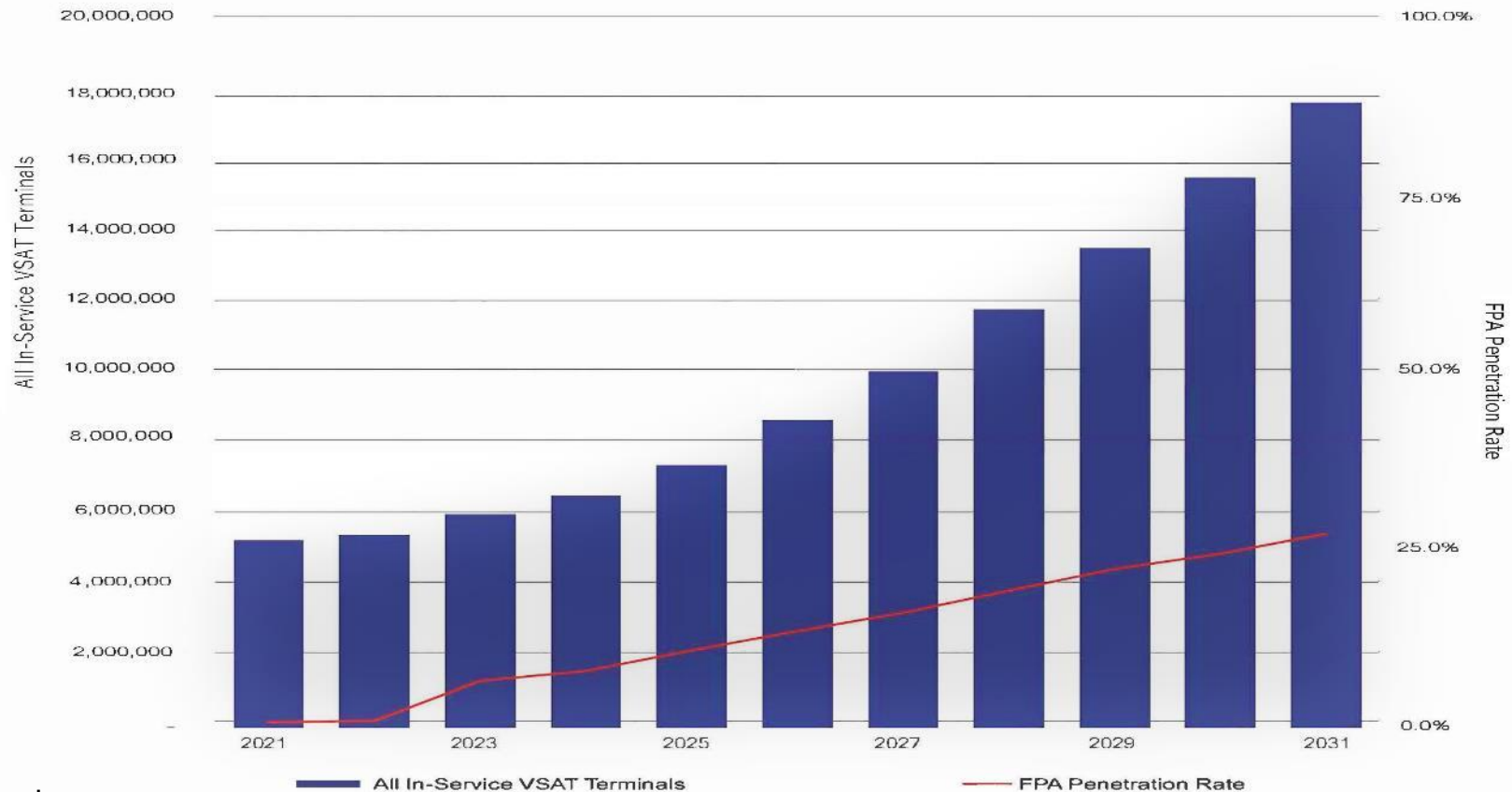

* Credit by NSR - Northern Sky Research

Modular and Scalable Flat Panel Ka Satcom Antennas in Development

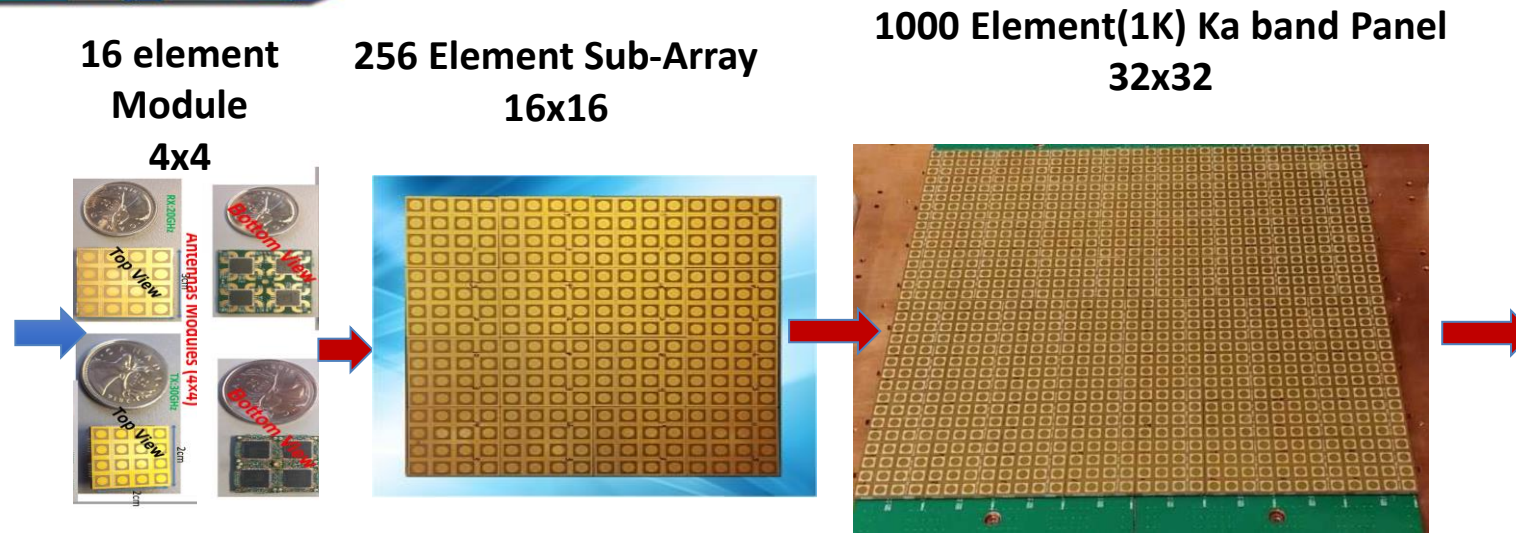

iNetVu® iNmotion ESA Antenna

Supports GEO, LEO, MEO
Constellations

Ka-band Frequency: Transmit: 27.5-
30.0 GHz Receive: 17.7-20.2GHz

Electronic Beam Steering and
Tracking

Elevation Angles: 20-90 deg; (70deg
from Boresight) with scan loss up to
5dB

Azimuth Angles: 360 deg Continuous

Polarization: Software switchable,
Linear (H/V) or CP (RH/LH)



Cars with ESA Antennas



High-Speed Trains with Phased Array Antennas



Simulation of Aircraft with Phased Array Antennas



Phased Array System for High Efficiency Millimeter Wave Wireless Communications of 37-48GHz



PARTNERS

- C-COM Satellite Systems Inc.
- Skyworks Solutions Canada Inc.
- University of Waterloo
- Eindhoven University of Technology
- NXP Semiconductors
- Semiconductor Ideas to the Market

COUNTRIES INVOLVED

- Canada
- Netherlands

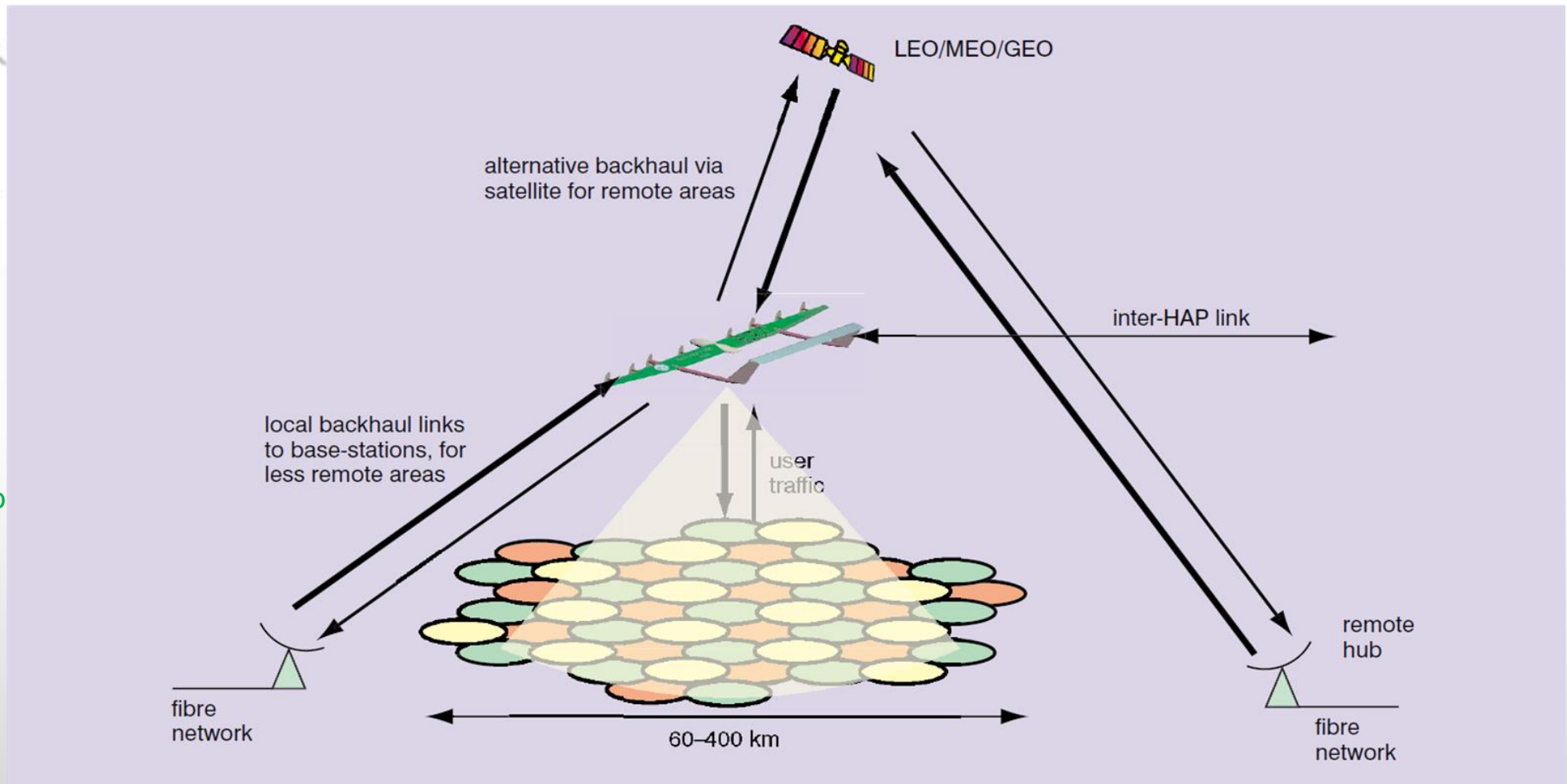

Phased Array System for High Efficiency Millimeter Wave Wireless Communications of 37-48GHz



- 5G services currently being rolled out in Europe and elsewhere are based on updated 4G systems.
- A host of Low-Earth Orbit Satellite constellations are now in deployment that will leverage ubiquitous coverage between the north and south poles.
- The biggest gains will come from the introduction of new mmWave technologies, which use radio waves of much higher frequencies and shorter wavelengths.
- These technologies are the key to improved network capacity, faster downloads (anywhere from 10 to 100 times) and reductions of up to 10-fold in 'latency' (i.e. the time to respond to an instruction or a command).
- Softbank HAPS Mobile Mission Concept: <https://www.hapsmobile.com/en/media/>

Emerging LEO/MEO Constellations and the growing need for Electronic Scanning Ground Terminals

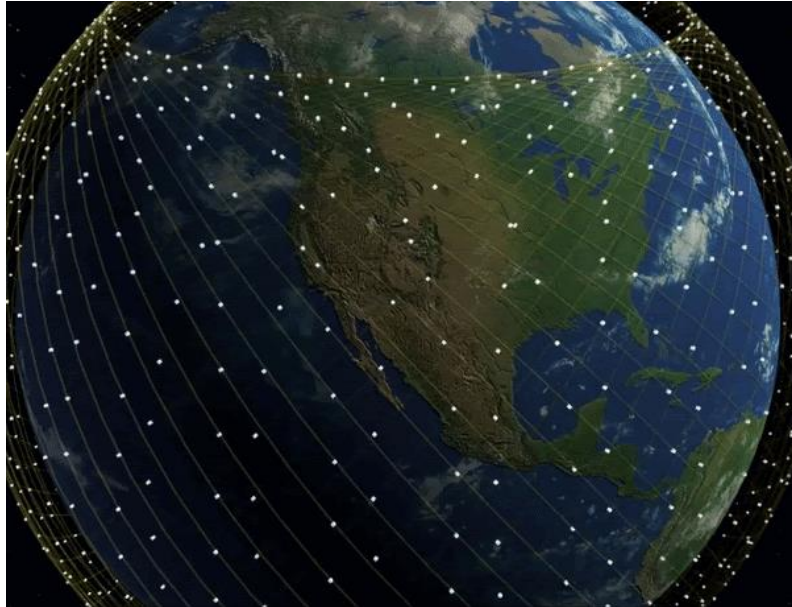

Canada TELESAT Lightspeed Constellation

Broadband LEO/MEO/GEO Satellite Connectivity on the Move

Integration of Silicon BFICs (a Key Component) into Antenna Modules

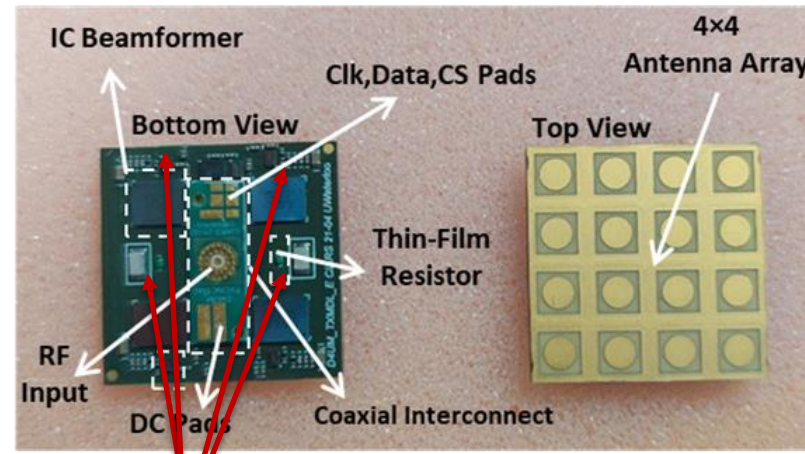
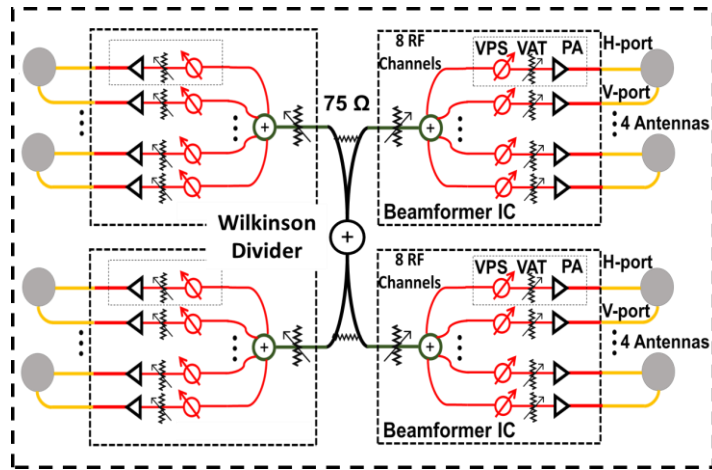

Multi-channel BFICs

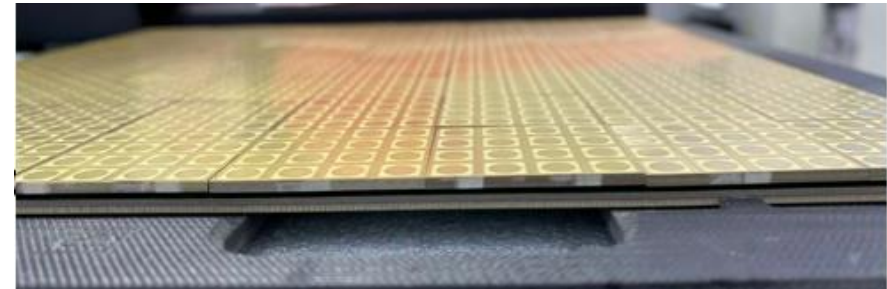

- ❑ TX frequency band : 27.50-31 GHz.
- ❑ RX Frequency band: 17.7-21.2GHz
- ❑ Programmable Polarization : LP (H/V) and CP (RH/LH).

C-COM Ka-band BFIC Evolution

World's Highest Performance, Lowest Power Consumption Satcom BFIC

Significant research and engineering development in developing high performance

Custom Satellite Chip

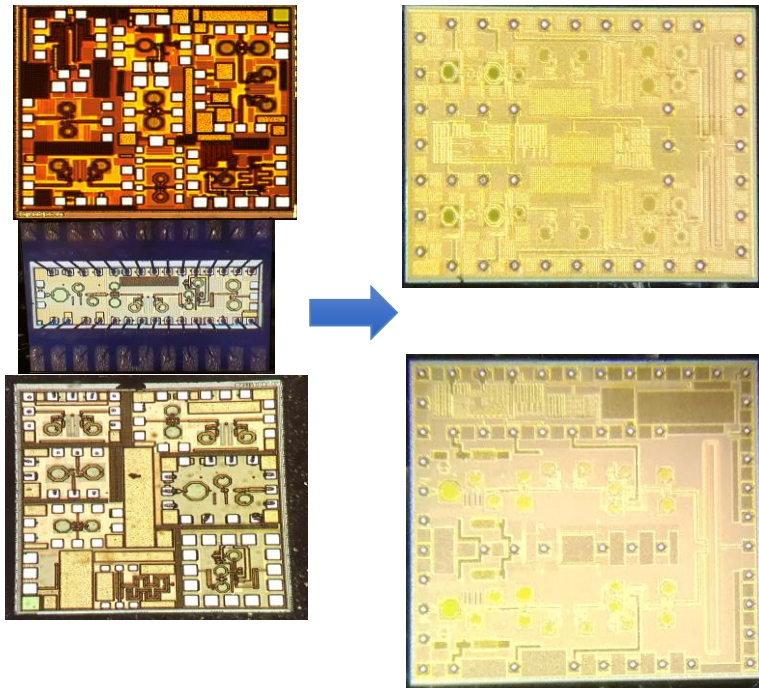

C-COM Multi-Channel Satcom BFIC

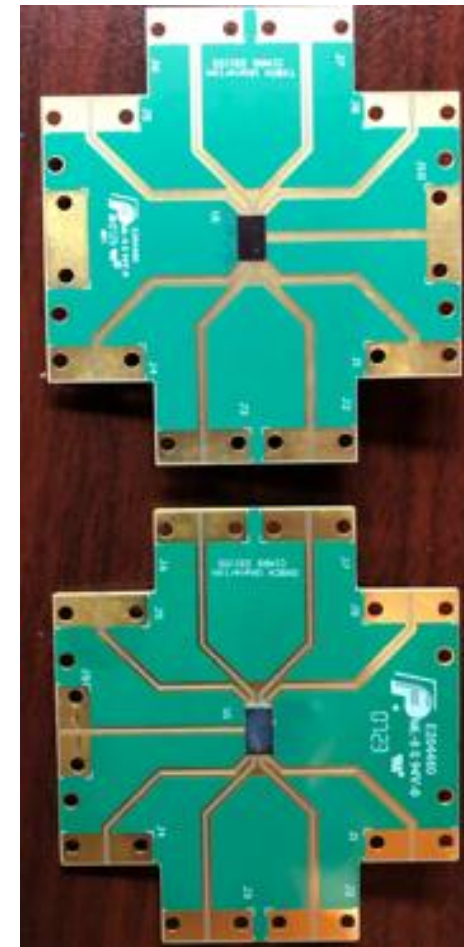

C-COM Ka-band BFIC in Development

World's Highest Performance, Lowest Power Consumption Satcom BFIC

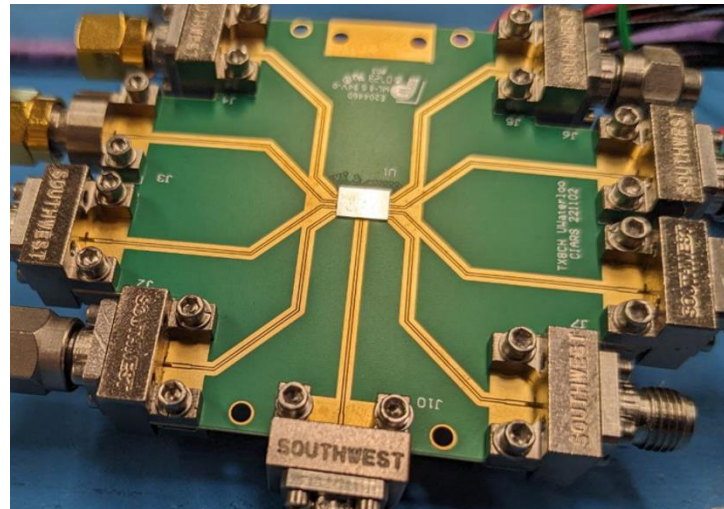
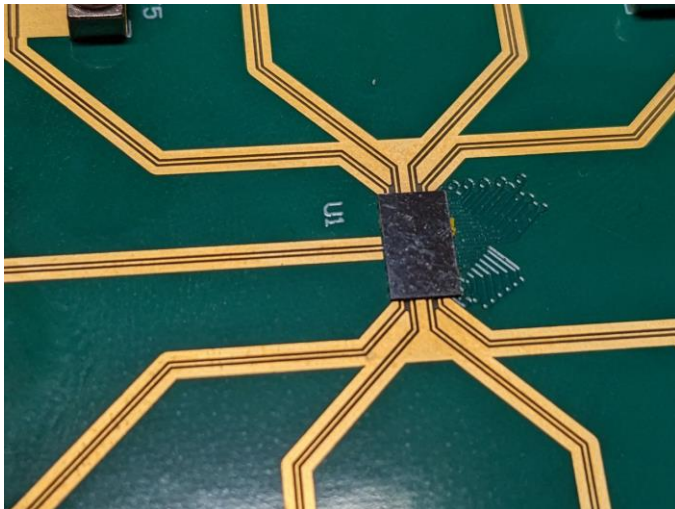
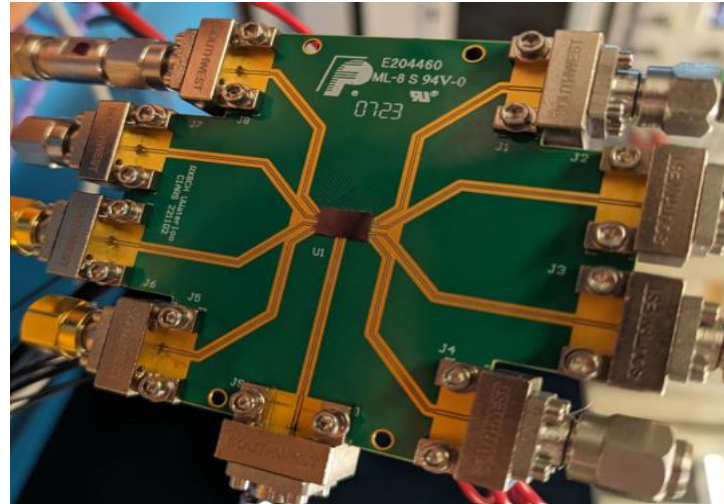
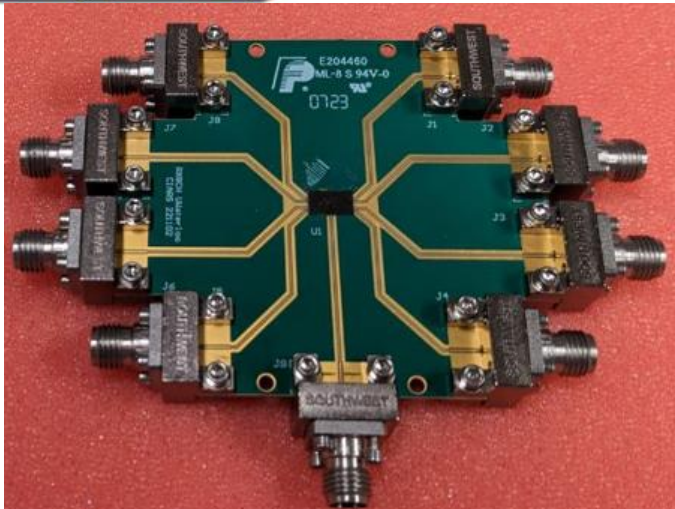

Thank You!



lklein@c-comsat.com

www.c-comsat.com